

OWNER'S MANUAL

Model: FSTS-60-12V (5301448-BLK) (5301448-BLU)
(60 Gallon Trailer Sprayer - Boom Ready)

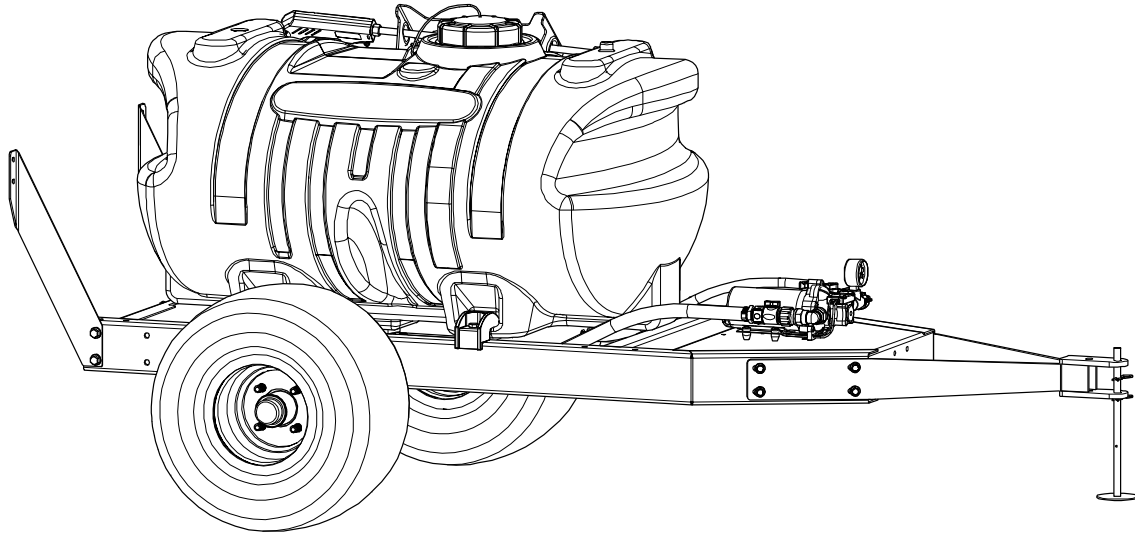

General Information

Thank you for purchasing this product. The purpose of this manual is to assist you in operating and maintaining your trailer sprayer.

BEFORE RETURNING THIS PRODUCT FOR ANY REASON, PLEASE CALL

BAKERSFIELD, CA 877-724-2236	COLUMBUS, NE 800-274-1025	DOTHAN, AL 800-227-4098
FARGO, ND 701-280-2862	HOPKINSVILLE, KY 800-637-7172	MANKATO, MN 507-388-6295
NEWTON, KS 800-394-7662	PASCO, WA 800-634-2026	TEMPE, AZ 877-974-7166

If you should have a question or experience a problem with your Ag Spray Product: Visit our website @ www.agspray.com or call the Toll free number above. Our technical support representatives will be happy to help you.

In most cases a customer service rep. can resolve the problem over the phone.

To obtain prompt, efficient service, always remember to give the following information....

- Correct Part Description and/or part number
- Model number and Serial Number

Part descriptions and numbers can be obtained from the illustrated parts list section(s) of this manual.

Retain a copy of your receipt for your unit, as it will be required to validate any warranty service.

Warranted against manufacturer or workmanship defects from date of purchase with copy of receipt:

Homeowner Usage: One Year

Commercial Usage: 90 Days.



WARNING: Cancer and Reproductive Harm.
www.P65Warnings.ca.gov



WARNING: To reduce the risk of injury, the user must read and understand the operator's manual before using this product.



NOTE: Maximum Speed - 10 MPH
Refer to vehicle's manual for towing instructions.

IMPORTANT REMINDER

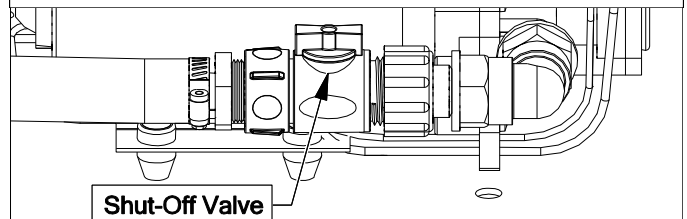

Shut-Off Valve

This sprayer comes with an On/Off valve located on your intake line. Make sure the valve is in the "open" position before using this sprayer.



www.agspray.com

[5194611

(12/22)]

Contents

Technical Specifications.....	2	Troubleshooting.....	6
Sprayer Assembly Instructions	3	Sprayer Dimensions	7
Operation	4	Sprayer Exploded Views.....	8 - 9
Maintenance, Tank Care and Winter Storage	5	Sprayer Parts List.....	9
Pump Exploded View and Parts List	6	Warranty	10

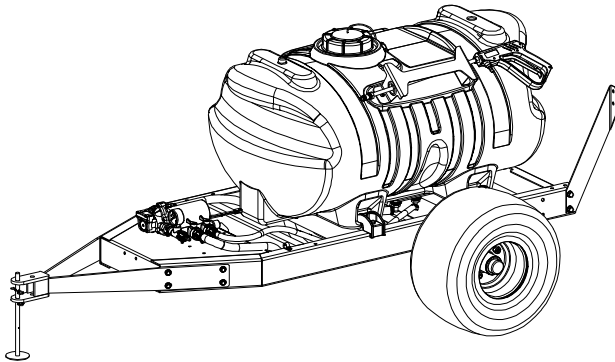

Model: FSTS-60-12V
(5301448-BLK) (5301448-BLU)
(60 Gallon Trailer Sprayer - Boom Ready)

Technical Specifications

- 60 Gallon Corrosion-Resistant Polyethylene tank
- 12 Volt Diaphragm Pump, 4.0 GPM, 45 PSI
- Deluxe Pistol Grip Handgun W/25' of Hose
- 26' Vertical Spray, 35' Horizontal
- Pneumatic Tires, 18 x 8.50 - 8
- Maximum Speed - 10 MPH

Caution: Always check the vehicle load rating before using the sprayer.

The loaded weight of this sprayer and boom assembly is approx.: 750 lbs. when the tank is full.

This sprayer is designed to be towed behind a garden tractor.

~~~~~IMPORTANT~~~~~

Remove tank lid and be sure the tank is clean and free of any foreign material. Rinse tank out of any tank residue before filling with water to test.

~~~~~IMPORTANT~~~~~

It is VERY important to test this sprayer with plain water before actual spraying is attempted. This will enable you to check the sprayer for leaks without the possibility of losing any expensive chemicals.

~~~~~WARNING~~~~~



Read and Understand the Owner's Manual completely before using this sprayer. Assemble, test and use in accordance to manual instructions.

Read and Follow chemical label instructions and wear protective gear when filling, using, cleaning and servicing the sprayer.

Exercise Caution in vehicle handling when towing/hauling a filled sprayer to avoid loss of control or overturning.

Keep Sprayer and Spray materials away from other people, children and pets.

Do Not Turn on Power to the sprayer, until ready to spray in order to avoid unintentional spray release.

Slow down before turning and do not turn sharply. Use wide turns to ensure sprayer follows path of towing vehicle.

Do Not Use on steep slopes. A full sprayer could cause loss of control or overturn sprayer and towing vehicle.

Always operate up and down a slope, never across the face of a slope.

Keep all movement on slopes slow and gradual. Do not make sudden changes in speed, directions or turning. Do not start or stop suddenly when going uphill or downhill.

Stop on level ground, set the parking brake and shut off engine before leaving the operator's position for any reason.

Keep all parts in good condition and properly installed. Fix damaged or worn parts immediately.

Caution should be taken when towing and/or using any sprayer. This sprayer combined with the weight distribution, turning radius and speed of towing vehicle can result in damage to towing vehicle and/or attachment or severe injury or death, if not used properly.

Improper use of this sprayer or handling of chemicals could result in serious injury or illness, or could cause damage to the environment.

Assembly Procedure

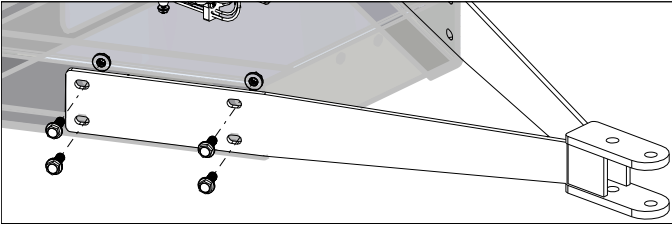

Step 1

Bolt the tongue to the skid, using (8) 3/8" x 1" hex flange locknuts and flange locknuts..

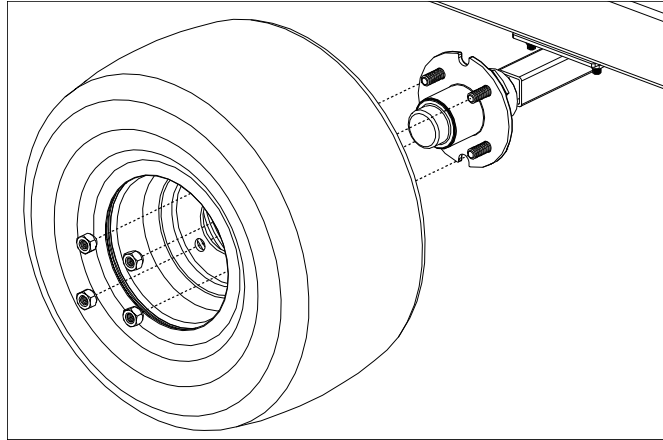

Step 2

Attach the axle to the trailer frame with (4) bolts & nuts as shown.

Step 3

Slide a wheel onto the hub of the axle and use the wheel nuts to hold the wheel in place. Repeat for other side.



NOTE: Maximum Speed - 10 MPH
Refer to vehicle's manual for towing instructions.

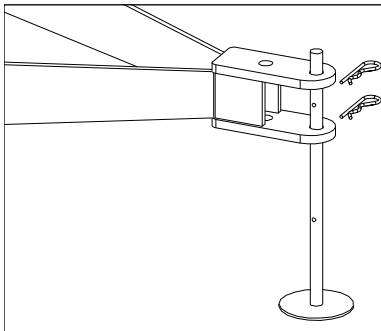

Step 4

Insert the stand weldment in the hitch and retain with hitch pins.

Step 5

Install the pressure gauge.
Hand tighten securely.
****DO NOT OVER-TIGHTEN****

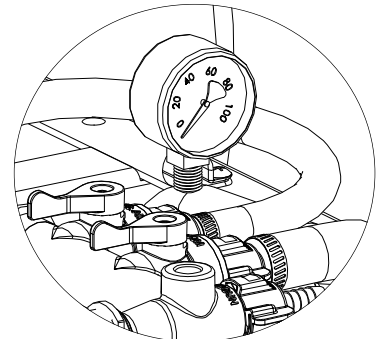

Step 6

If attaching a boom, attach the boom mounts and feeder hose. Left Hand (LH) and Right Hand (RH) sides of the sprayer are determined as if you are standing behind the sprayer, looking at it (facing forward)

Mount the (LH) and (RH) boom mounts to the back of the frame (If not already done).

Locate both the (LH) & (RH) boom mounts, (4) 3/8"-16 x 3/4" bolt and (4) 3/8"-16 flanged whiz nuts.

Attach the boom mounts to the frame. Make sure the brackets are parallel with each other before tightening down the bolts.

Finally, attach the feeder hose to the hose barb on the manifold and the fitting on your boom.

- Make sure all hose clamps are tight before testing or spraying for the first time.
- One requirement will be for you to hook up your battery leads to a fully charged 12 Volt battery.

****The Sprayer is now ready to TEST w/plain water before actual use****

IMPORTANT: Remove tank lid and be sure the tank is clean and free of any foreign material. Rinse tank out of any tank residue before filling with water to test.

Testing the Sprayer

NOTE:

It is VERY important to test this sprayer with plain water before actual spraying is attempted. This will enable you to check the sprayer for leaks without the possibility of losing any expensive chemicals.

Fill the tank about 1/2 full with plain water and drive to the starting place for spraying.

When you are ready to spray, turn the boom valve to the “on” position (Detail A). This will start solution spraying from the tips of the boom. The pressure will decrease slightly when the boom is spraying.

Adjust the pressure by turning the “ON/OFF” valve lever on the Press. Adj. (bypass) line valve (Detail B). Make sure your pattern is sufficient. You may down-pressure the system by ‘bypassing’ solution back into the tank. This is achieved by opening the Press. Adj. (bypass) valve. Regulating pressure is done in this manner.

Read the operating instructions and initially begin spraying by closing the ‘Pressure Adjust’ valve and opening the boom line valve (Detail A). This will enable the air in the line to be eliminated (purged) through all the tips, while building pressure. When everything tests all right (no leaks and good pressure), add the desired chemicals to the mixture and water combination and start your spraying operation. Adjust the pressure and spray as you did in the testing procedure.

Conditions of weather and terrain must be considered when setting the sprayer. Do not spray on windy days. Protective clothing must be worn in some cases.

Be sure to read the chemical label(s) before application!

Operation

The pumping system draws solution from the tank, through the strainer and to the pump. The pump forces the solution under pressure to the handgun or boom nozzles.

Fill the tank part way with water and then add the desired amount of chemical to be sprayed. Finish filling tank to proper level.

Only fill the tank with what you’re going to spray in a day, never leave chemicals sit in tank.

Connect the lead wire to a fully charged 12 volt battery. You may use either a stand-alone battery or the battery on your towing vehicle. Connect to the positive (red) terminal first, then connect to the negative (black) terminal. Then connect the end of the lead wire to the end of the pump. When disconnecting, disconnect the end of the pump wire from the lead wire, then disconnect the negative (black) connection and finally the positive (red) connection. The lead wire has an On/Off switch to activate the pump. “-” is on and “O” is off. Turn the pump on by depressing the “-” side of the rocker switch.

The pump is equipped with a pressure switch that is pre-set at the factory to shut the pump off when all discharges are closed.

The pump will turn back on when one of the following actions occurs:

- ◆ Handgun lever is squeezed to spray the handgun.
- ◆ Boom valve is opened to broadcast spray with the boom.
- ◆ Bypass valve is opened to re-circulate solution back into the tank.

When spraying with either the boom or the handgun, pressure may be reduced by slowly opening the bypass valve until desired pressure is achieved. Opening the valve decreases pressure, closing the valve increases pressure. When spraying with the boom, the proper method to set the pressure is to open the boom valve completely and if a lower pressure is desired, then slowly open the bypass valve until that pressure is obtained.

For the safest and most efficient chemical application, you will need to calibrate your sprayer using the tip and speed charts, follow instructions in your boom manual. Once you have determined the proper speed and pressure settings, you will need to consult your chemical label for the amount of chemical to be added to the tank. Read the entire label. Use only according to label directions.

Manifold Valves CLOSED

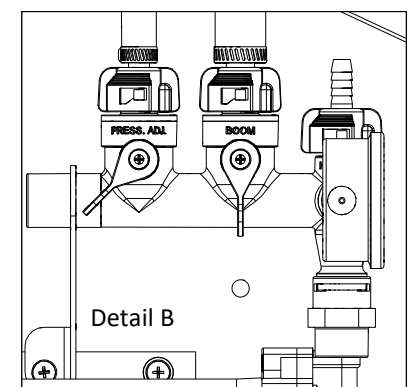
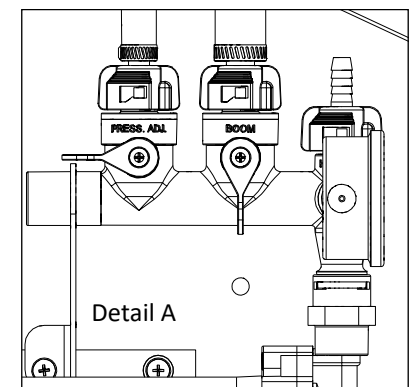
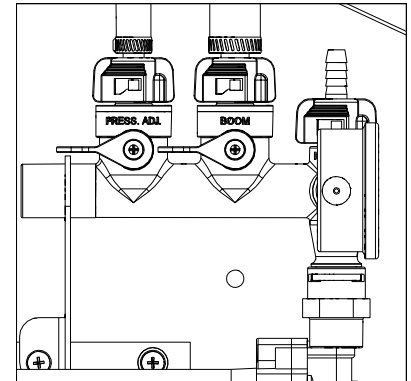

Using Boom Nozzles

Four things must be considered before spraying with a boom.

1. How much chemical must be mixed in the tank.
 2. Rate of spray (gallons per acre to be sprayed).
 3. What pressure (p.s.i.) will be used.
 4. Speed traveled (mph) while spraying.
- * Refer to the chemical label to determine your chemical mixture
 - * See the tip chart to determine the pressure to be used. The chart will also show the speed used when spraying.
 - * Start the pump and open the valve to the boom nozzles.
 - * Check the spray pattern. Usually you can see the coverage better on a solid concrete surface, such as a driveway.

Maintenance During/After Spraying

Periodically check the strainer and clean the screen on your intake line.

If sprayer becomes clogged during use, discontinue use immediately. DO NOT attempt to service while chemicals are in the sprayer and power is connected.

Proper care and maintenance will prolong the life of your sprayer.

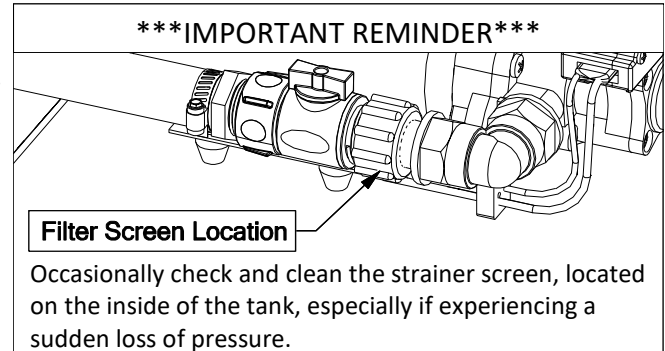

After use, drain the tank and store or dispose of chemical properly. Fill the sprayer half way with clean water. Start the pump and allow the water to pump through the entire plumbing system and nozzles. Drain and then refill half full, add the recommended amount of a good quality tank cleaner, such as FIMCO Tank Neutralizer and Cleaner. (If no tank cleaner is available, you may substitute dish soap for this step, about 1-2 oz. per gallon). But a neutralizer/cleaner should be used to thoroughly clean the system. Turn pump on and circulate through system for 15 minutes and then spray out through boom and handgun nozzles. Refill sprayer half way with clean water and repeat. Follow the chemical manufacturer's disposal instructions of all wash or rinsing water. If boom (if applicable) or handgun nozzles need cleaning, remove them from the sprayer and soak in warm soapy water. Clean with a soft bristled brush or toothpick if necessary. Never use a metal object. Even the slightest damage can change the flow rate and spray distribution. Water rinse and dry the tips before storing.

WARNING: Some chemicals will damage the pump valves if allowed to soak untreated for a length of time! ALWAYS flush the pump as instructed after each use. DO NOT allow chemicals to sit in the pump for extended times of idleness. Follow the chemical manufacturer's instructions on disposal of all waste water from the sprayer.

Tank Care & Maintenance

Warning: Do not use the tank as a container for fuel oils, kerosene, gasoline or any other petroleum distillate product. All polyolefins are softened and permeated by such products. In an enclosed area the vaporization of these materials from the outside surface of the tank could create a dangerous condition.

The tank should not be used as a pressure vessel nor used with chemicals or solutions having a weight of more than 12 pounds per gallon.

Store the tank in a dry dark place when not in use. Storage out of sunlight will prolong the life of the tank.

Do not drop, strike or kick the tank, especially at low temperatures. Tanks become brittle and are subject to cracking at temperatures below 20° Fahrenheit.

Always flush the tank with water and a neutralizing agent at the end of each use, to prevent contamination of solutions.

Winter Storage

Prepare the sprayer for end-of-season storage by running RV antifreeze through the system. This will keep internal parts lubricated, protect against corrosion and keep the unit from freezing. *Note: RV antifreeze is non-toxic and biodegradable and generally safer for the environment than automotive antifreeze.*

Before storing your sprayer for winter or long term storage, thoroughly clean and drain it as much as possible. Then pour enough pink RV antifreeze into the tank so that when the pump is turned on you can pump the antifreeze throughout the entire plumbing system, including the bypass. Make sure to operate the handgun until you see pink fluid spraying from the nozzle. Leave any remaining antifreeze in the tank. Before your next usage, rinse the antifreeze from the sprayer with clean water.

It is nearly impossible to drain all of the water from the sprayer and any trapped water can freeze in cold weather and damage parts of the sprayer. Pumping the antifreeze through the system will displace the water and help prevent this damage.

Removing from storage: drain the antifreeze. Fill the tank with fresh water and run through the system. Dispose of antifreeze and flush water properly.



- Clean and rinse pump after each use with Fimco Tank Neutralizer
- Winterize pump or sprayer by rinsing, draining and running RV Antifreeze through it before storing for the winter.
- Use clean water for your spray mixture
- Store inside a building when not in use.



- Use to pump bleach.
- Use to pump petroleum products such as diesel fuel, gasoline or kerosene.
- Use to pump chemicals w/petroleum distillates or surfactants.
- Leave pump sit with spray mixture in it for extended periods.
- Use dirty or unfiltered water for spraying.

Ref. #	Mfg. Part #	Description	Qty.
1	94-230-56	Pressure Switch Assembly	1
2	94-237-05	Check Valve Assembly	1
3	94-231-30	Upper Housing	1
4	94-232-05	Valve Assembly	1
5	94-226-17	Drive Assembly	1

Base Plate Grommets (Pkg/4): #5075019

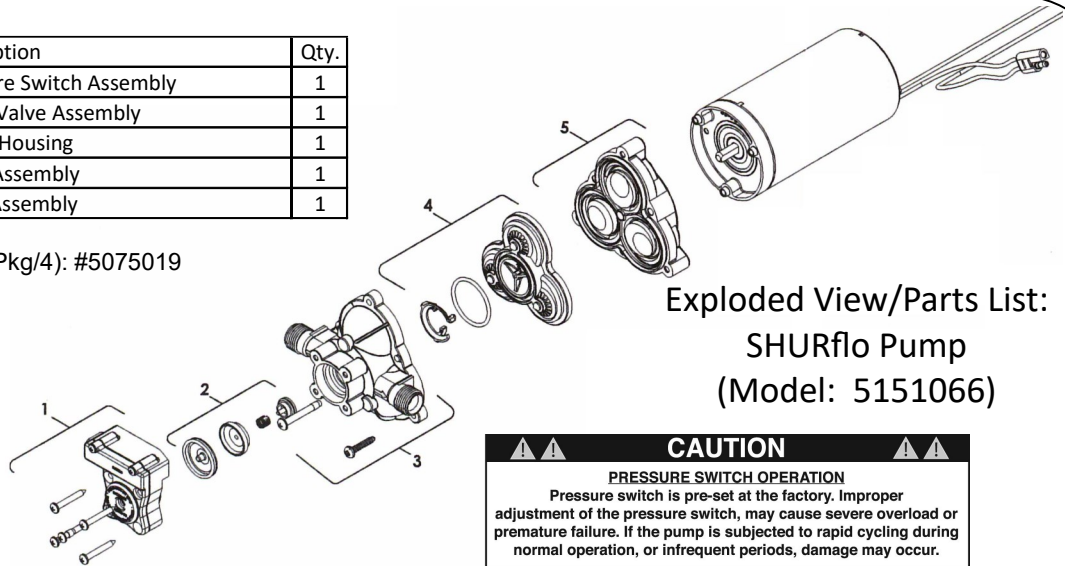

Exploded View/Parts List:
SHURflo Pump
(Model: 5151066)

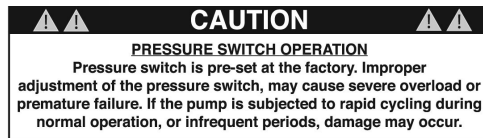

Before Troubleshooting or Attempting to Service the Pump:

- ◆ **Review Troubleshooting Chart:** Do Not attempt to repair until steps below are followed.
- ◆ **Personal Protective Gear:** Wear protective gear when servicing pump.
- ◆ **Disconnect Power:** Disconnect the power to the pump and relieve the pressure from the system.
- ◆ **Empty and Flush** the pump system with water, never attempt to service the pump until it has been emptied and flushed.
- ◆ **Perform Repairs:** Follow directions provided in the troubleshooting section to repair the pump.
- ◆ **Test:** Always test the pump for leaks with plain water after any repairs before using.

Troubleshooting	
Pump will not run:	Check for loose wiring
	Make sure the ON/OFF switch is on
	Check the fuse
	Check for defective pressure switch
	Check to see if connected to good 12 Volt Power Source
	Check for Low Voltage
Pump Does Not Prime (No Discharge w/Motor Running)	Check for clogged strainer/filter
	Check for kinked inlet/outlet hoses
	Check for empty product supply
	Check for debris in check valve assembly
	Check for defective check valve
	Check for cracks in the pump housing
Low Pressure/ Low Flow:	Check for air leaks in supply line
	Check for a clogged strainer
	Check for proper voltage Try another 12-Volt battery
	Check for leaks in the discharge line
	Check for restrictions in the discharge line
	Check for debris in intake
Pump surges:	Check for debris in nozzle orifice
	Discharge hose may be too long
	Check for clogged strainer/filter
	Check for restriction in discharge line
	Check for defective pressure switch
	Check for leaks in the discharge line
Pump continues to run:	Check for empty product supply
	Check for Low Voltage
	Check for leaks in the discharge line
	Check for defective pressure switch
	System has leaks
	Air trapped in outlet line or pump head
Fuse blows:	Check for open bypass valve (if equipped)
	Check for defective or dirty check valve
Improper adjustment of pressure switch	Excessive voltage
	Damaged or defective wiring harness
	Defective pressure switch

Approx. Dimensions

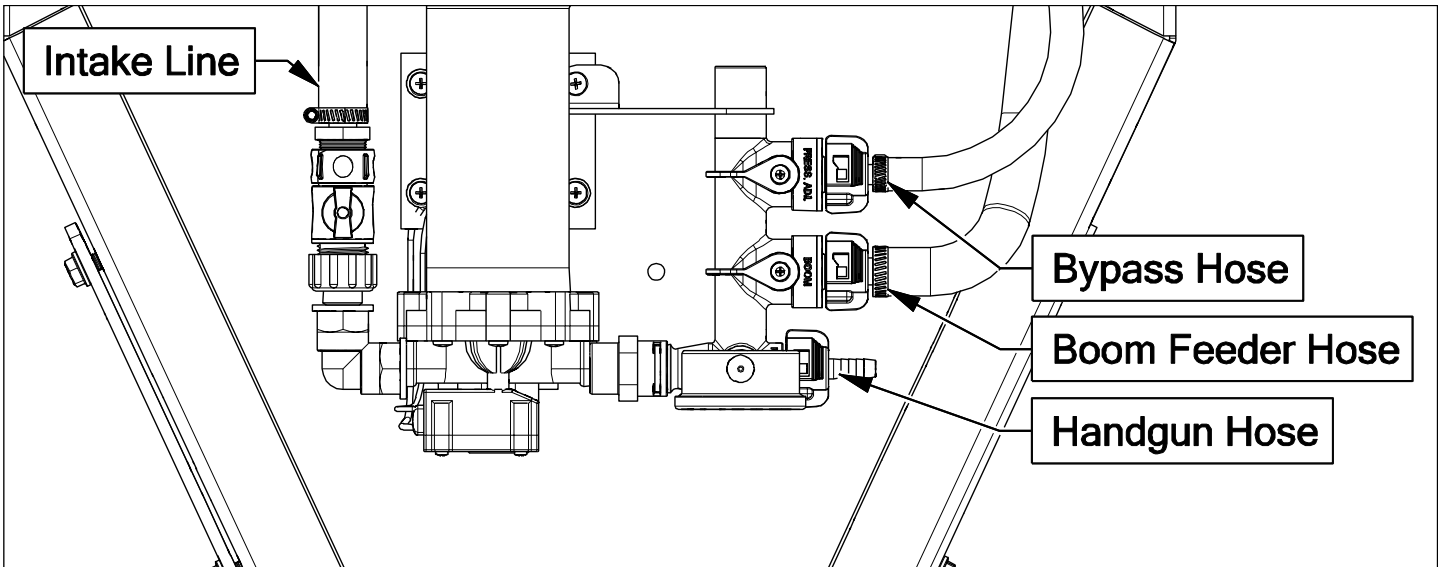
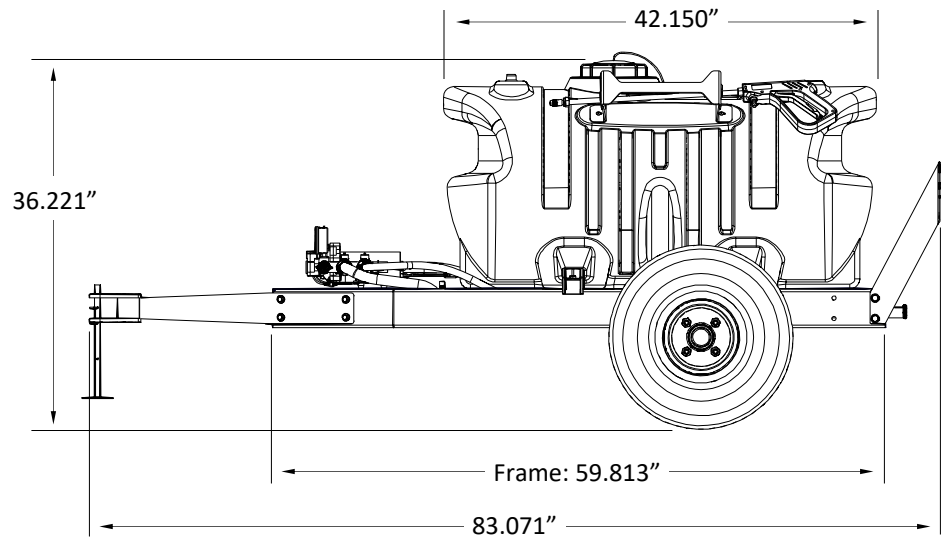
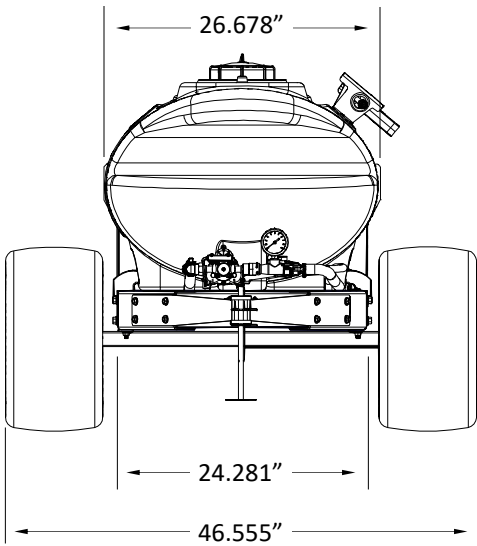

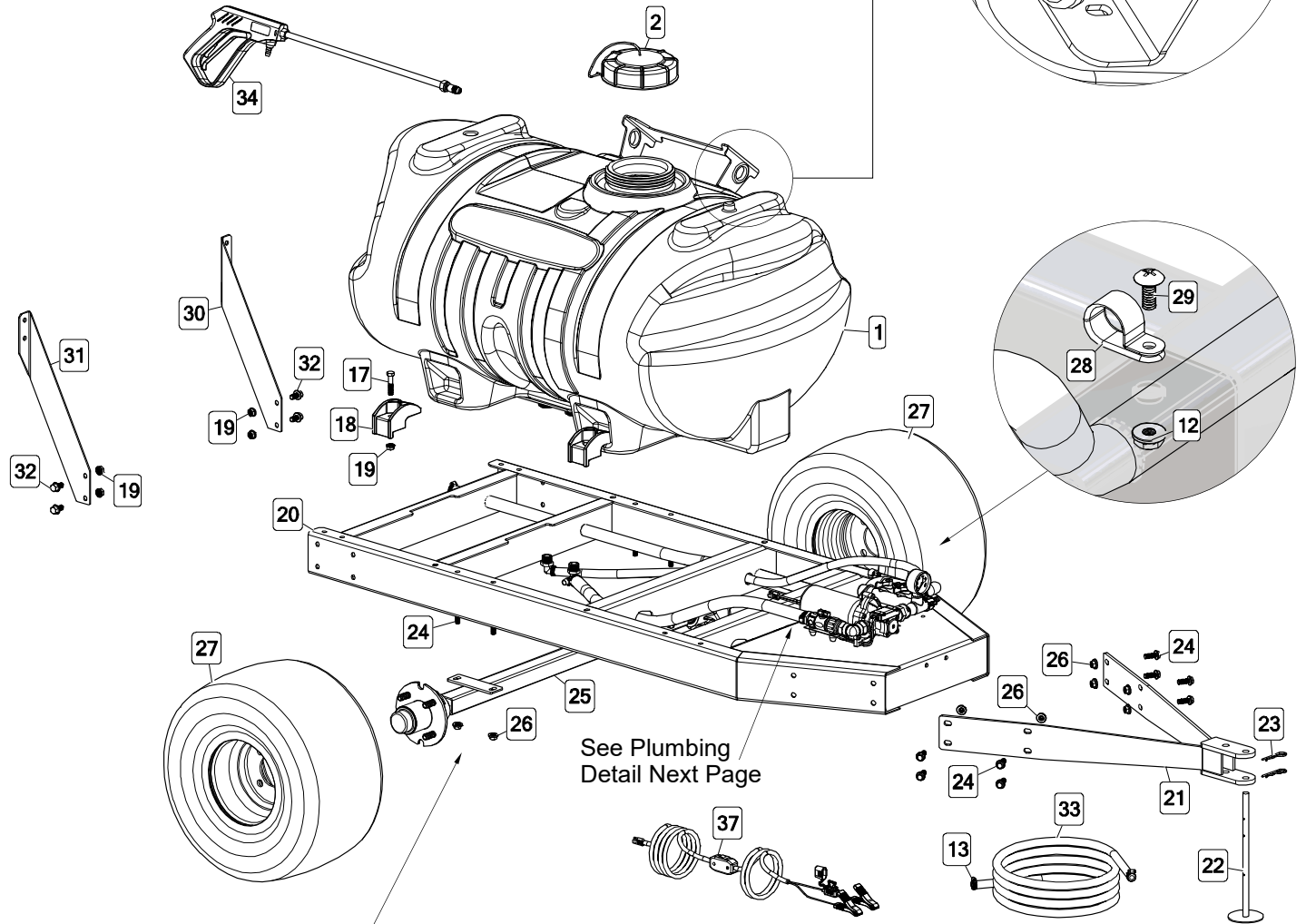
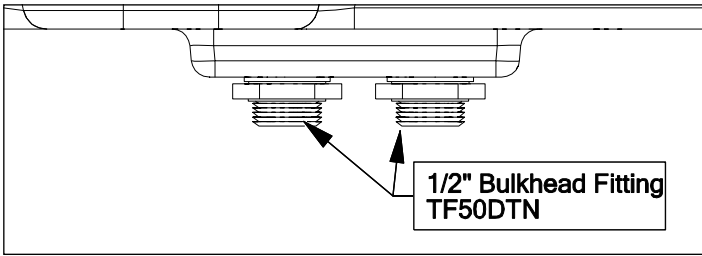

**Exploded View: FSTS-60-12V
(5301448-BLK) (5301448-BLU)**

Refer to Parts List Next Page for Part Numbers

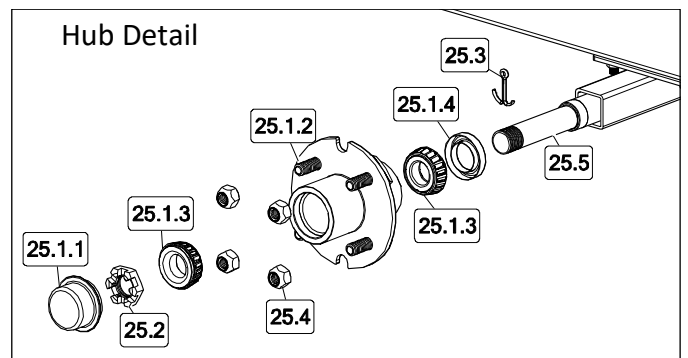
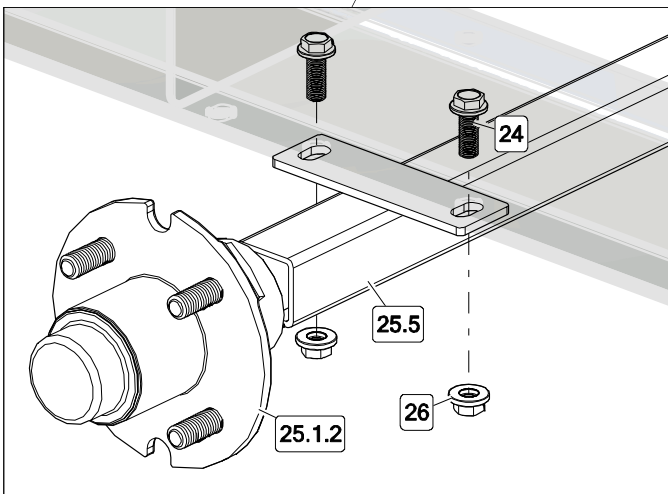

Parts List: FSTS-60-12V (5301448-BLK) (5301448-BLU)

Ref. #	Part #	Description	Qty
1	5169250	60 Gallon Elliptical Tank (Yellow)	1
1.1	TF50DTN	1/2" Bulkhead Fitting Assembly	2
2	5058188	Tank Lid w/Lanyard	1
3	5010203	Poly Elbow, 1/2" MNPT x 1/2" HB	1
4	5020228	Hose, 1/2"-1 Brd. x 36"	1
5	5051114	Hose Clamp (1/2")	4
6	5281364	SHURflo 4.0 Pump Assembly	1
6.1	5280362	SHURflo Plumbing Assembly	1
6.1.1	5067121	Poly Hose Fitting, 3/4" MGHT 1/2" HB	1
6.1.2	5143419	Swivel Shut-Off	1
6.1.3	5116242	Strainer, 1" Filter Washer	1
6.1.4	5005287	Poly Swivel Adapter Spud, 1/2" NPT	1
6.1.5	5006209	Poly Knurled Swivel Nut, 3/4" FGHT	1
6.1.6	5010236	Poly Elbow, 1/2" FNPT x 1/2" FNPT	1
6.2	5151066	SHURflo Pump: 12V, 4 GPM, 45 PSI	1
6.3	5117166	#10-24 x 1 1/4" PH Truss Head Screw	3
6.4	5005456	3/4" Port to 1/2" Female NPT Adapter	1
7	5005457	Port Adapter Clip	1
8	5302350	Quick Connect Manifold Assembly	1
8.1	5302347	Quick Connect Manifold (Body)	1
8.1.1	5072514	O-Ring - Pump Port Connection	1
8.1.2	5143421	Quick Connect Manifold - Handle	2
8.2	5143430	Flat Washer Hose Barb Seal	3
8.3	5143431	QC Manifold - 3/8" Hose Straight Barb	2
8.4	5143432	QC Manifold - 1/2" Hose Straight Barb	1
8.5	5143429	Quick Connect Quarter Turn Cap	3
9	5037943-BLK	Manifold Support Brace	1
10	5117166	#10-24 x 1 1/4" PH Truss Head Screw	1
11	5167007	Gauge, Dry, 0-100 PSI	1
12	5006186	#10-24 Hex Fling Whiz Nut, ZP	5
13	5051144	Hose Clamp (3/8")	4
14	5020538	Hose, 3/8"-1 Brd. x 43"	1
15	5010202	Poly Elbow, 1/2" MNPT x 3/8" HB	1

Ref. #	Part #	Description	Qty
16	5020167	Hose, 1/2"-1 Brd. x 90"	1
17	5034101	3/8"-16 x 1 3/4" Hex Bolt	4
18	5038698	Plastic Tank Hold-Down Leg Clip	4
19	5006259	3/8-16nc Hex Fling Whiz Nut	8
20	5278082-*	60 Gallon Skid (Specify -BLK or -BLU)	1
21	5274957-BLK	Tongue Weldment (60 Gallon Skid)	1
22	5272092-BLK	Stand Weldment	1
23	5101065	#211 Hitch Pin Clip (Zinc Plated)	2
24	5117307	3/8"-16 x 1" Whiz (Fling) Lockscrew	12
25	5274955	Axle & Hub Assembly	1
25.1	5272465	Hub Assembly, 4-Bolt	2
25.1.1	5046327	Grease Cap	1
25.1.2	5085018	Hub Assembly (4-Stud)	1
25.1.3	5031139	Cone Bearing	2
25.1.4	5072471	Grease Seal	1
25.2	5006300	Castle Nut, 1"	2
25.3	5101081	Cotter Pin, 5/32" x 2-1/4"	2
25.4	5006301	1/2"-20 Hex Cone Wheel Nut	4
25.5	5274954-BLK	Axle Weldment	1
26	5006259	3/8"-16 Hex Whiz (Fling) Locknut	12
27	5272464-SVR	Wheel, 18 x 8.5 - 8 - 4-Bolt	2
28	5051122	5/8" Black Nylon Loom Cable Clamp	1
29	5117234	#10-24 x 1/2" PH Truss Head Screw	3
30	5038831-BLK	Boom Mount Bracket (LH)	1
31	5038835-BLK	Boom Mount Bracket (RH)	1
32	5034660	3/8"-16 x 3/4" Fling Hex Bolt	4
33	5020527	Hose, 3/8"-1 Brd. x 25 Ft.	1
34	5273959	Deluxe Pistol-Grip Handgun w/X-26 Tip	1
34.1	5018331	Brass Handgun Tip (X-26)	1
35	5038775-BLK	Handgun Bracket	1
36	5075014	Rubber Grommet (Black)	2
37	5277040	Lead Wire (14 ga, w/Switch), 120"	1

-* = Specify -BLK (Black) or -BLU (Blue)

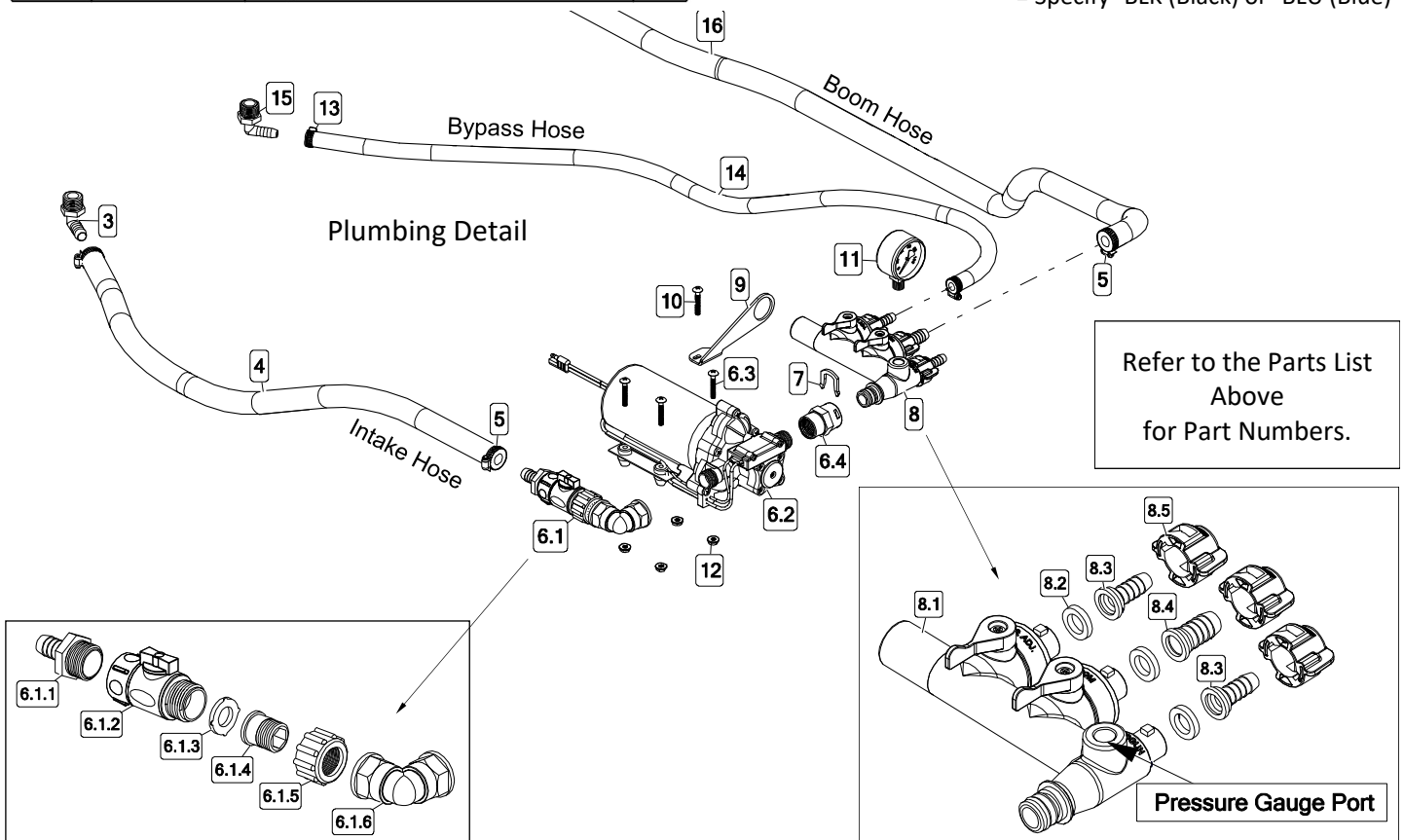

Warranty

LIMITED WARRANTY FOR NEW AG SPRAY EQUIPMENT

WHO MAY USE THIS LIMITED WARRANTY. This limited warranty (the "Limited Warranty") is provided by Ag Spray Equipment to the original purchaser ("you") of the Equipment (as defined below) from Ag Spray Equipment or one of Ag Spray Equipment's authorized dealers. This Limited Warranty does not apply to any subsequent owner or other transferee of the Equipment. THIS LIMITED WARRANTY GIVES YOU SPECIFIC LEGAL RIGHTS, AND YOU MAY ALSO HAVE OTHER RIGHTS WHICH VARY FROM STATE TO STATE.

WHAT THIS LIMITED WARRANTY COVERS AND FOR HOW LONG. Ag Spray Equipment warrants that any new Equipment will be free from defects in material and workmanship for a period of **one (1) year** (homeowner), **90 days** (commercial user), after delivery of the Equipment to you (the "Warranty Period"). The Warranty Period is not extended if Ag Spray Equipment repairs or replaces the Equipment.

WHAT IS NOT COVERED BY THIS LIMITED WARRANTY. This Limited Warranty does not apply to: (1) used Equipment; (2) any Equipment that has been altered, changed, repaired or treated since its delivery to you, other than by Ag Spray Equipment or its authorized dealers; (3) damage or depreciation due to normal wear and tear; (4) defects or damage due to failure to follow Ag Spray Equipment's operator's manual, specifications or other written instructions, or improper storage, operation, maintenance, application or installation of parts; (5) defects or damage due to misuse, accident or neglect, "acts of God" or other events beyond Ag Spray Equipment's reasonable control; (6) accessories, attachments, tools or parts that were not manufactured by Ag Spray Equipment, whether or not sold or operated with the Equipment; or (7) rubber parts, such as tires, hoses and grommets.

HOW TO OBTAIN WARRANTY SERVICE. To obtain warranty service under this Limited Warranty, you must (1) provide written notice to Ag Spray Equipment of the defect during the Warranty Period and within **thirty (30) days** after the defect becomes apparent or the repair becomes necessary, at the following address: Ag Spray Equipment, 1000 Fimco Lane, North Sioux City, SD 57049; and (2) make the Equipment available to Ag Spray Equipment or an authorized dealer within a reasonable period of time. For more information about this Limited Warranty, please call: **800-274-1025** or your local Ag Spray location.

WHAT REMEDIES ARE AVAILABLE UNDER THIS LIMITED WARRANTY. If the conditions set forth above are fulfilled and the Equipment or any part thereof is found to be defective, Ag Spray Equipment shall, at its own cost, and at its option, either repair or replace the defective Equipment or part. Ag Spray Equipment will pay for shipping and handling fees to return the repaired or replacement Equipment or part to you.

LIMITATION OF IMPLIED WARRANTIES AND OTHER REMEDIES. THE REMEDIES DESCRIBED ABOVE ARE YOUR SOLE AND EXCLUSIVE REMEDIES, AND AG SPRAY EQUIPMENT'S SOLE LIABILITY, FOR ANY BREACH OF THIS LIMITED WARRANTY. TO THE EXTENT APPLICABLE, ANY IMPLIED WARRANTIES, INCLUDING, WITHOUT LIMITATION, THE IMPLIED WARRANTIES OF MERCHANTABILITY AND FITNESS FOR A PARTICULAR PURPOSE, SHALL BE LIMITED IN DURATION TO THE WARRANTY PERIOD, AND THE REMEDIES AVAILABLE FOR BREACH THEREOF SHALL BE LIMITED TO THE REMEDIES AVAILABLE UNDER THIS EXPRESS LIMITED WARRANTY. SOME STATES DO NOT ALLOW LIMITATIONS ON HOW LONG AN IMPLIED WARRANTY LASTS, SO THE ABOVE LIMITATION MAY NOT APPLY TO YOU. IN NO EVENT SHALL AG SPRAY EQUIPMENT'S LIABILITY UNDER THIS LIMITED WARRANTY EXCEED THE ACTUAL AMOUNT PAID BY YOU FOR THE DEFECTIVE EQUIPMENT, NOR SHALL AG SPRAY EQUIPMENT BE LIABLE, UNDER ANY CIRCUMSTANCES, FOR ANY CONSEQUENTIAL, INCIDENTAL, SPECIAL OR PUNITIVE DAMAGES OR LOSSES, WHETHER DIRECT OR INDIRECT. SOME STATES DO NOT ALLOW THE EXCLUSION OR LIMITATION OF INCIDENTAL OR CONSEQUENTIAL DAMAGES, SO THE ABOVE LIMITATION OR EXCLUSION MAY NOT APPLY TO YOU.